

GREEN ENERGY DIVISION

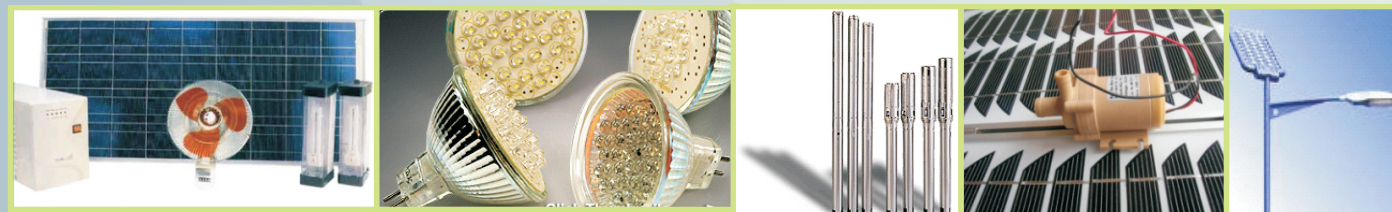

Benefits of Solar & Wind Energy

- * Reduces climate change and other environmental pollution
 - * Solar & Wind energy can be utilised as a shield against ever increasing power prices. The cost per kwh reduces over a period of time as against rising cost for conventional power projects.
 - * Diversifies energy supply, eliminates imported fuels, provides a hedge against the price volatility of fossil fuels. Thereby provides energy security and prevention of conflict over natural resources
 - * One of the cleanest source of electrical energy.
- Least equity participation required, as well as low cost debt is easily available to these energy projects.
- * A real fast track power project, with the lowest gestation period; and a modular concept.
 - * Operation and Maintenance (O&M) costs are low.
 - * Minimum marketing risks, as the product is electrical energy.
 - * Creates employment, regional growth and innovation
 - * Reduces poverty through improved energy access
 - * Fuel source is free, abundant and inexhaustible
 - * Delivers utility-scale power supply



BLACKIE HOUSE, 1ST FLOOR, W.H. MARG, OPP. G.P.O., NEAR CST, MUMBAI - 400 001.
 Ph: + 91 22 2270 0307 / 2270 0653 / 4 • Fax: +91 22 2261 0803 • Email: sales@steelitegroup.com
 Website : www.steelitegroup.com

RENEWABLE ENERGY WITH COMPLETE SOLUTION

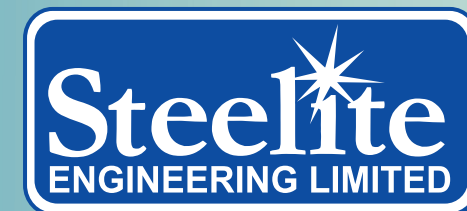

GREEN ENERGY DIVISION

Eco POWER SOLUTION

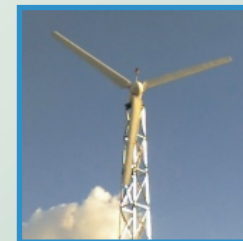

Power Energy
at your doorstep.....



BLACKIE HOUSE, 1ST FLOOR, W.H. MARG, OPP. G.P.O., NEAR CST, MUMBAI - 400 001.
 Ph: + 91 22 2270 0307 / 2270 0653 / 4 • Fax: +91 22 2261 0803 • Email: sales@steelitegroup.com
 Website : www.steelitegroup.com

Wind Energy Growing concern for the environmental degradation has led to the world's interest in renewable energy resources.

Wind is commercially and operationally the most viable renewable energy resource and accordingly, emerging as one of the largest source in terms of the renewable energy sector.

What is wind energy?

Wind is the natural movement of air across the land or sea.

Wind is caused by uneven heating and cooling of the earth's surface and by the earth's rotation. Land and water areas absorb and release different amount of heat received from the sun. As warm air rises, cooler air rushes in to take its place, causing local winds. This wind can be tapped to run wind generators to produce ELECTRICITY which can be made available for commercial and residential use.

Wind Generators can be used as stand alone systems or can be connected to utility grid.



ENERGY EFFICIENT DEVICES

- Wind / Solar / Hybrid powered water pumps.
- Wind / Solar / Hybrid powered LED lights for Interior and exterior use.
- Wind / Solar / Hybrid powered Home light kits.
- Solar Hot water systems.
- LED Lights



ENERGY EFFICIENT DEVICES - LED

- LED Lights
- Available for both indoor & outdoor use.
- 5 w LED equivalent to 50 w tube light or 11 w CFL.
- Life up to 1,00,000 hours.
- Highly efficient & durable.



APPLICATIONS

- Power for Construction, security, fencing etc.
- Street lights.
- Wind / Solar / Hybrid powered LED lights for Interior and exterior use.
- Wind / Solar / Hybrid powered Home light kits.
- Solar Hot water systems.
- LED Lights



OFF GRID MINI WIND GENERATORS

- Mini Wind Generators.
- Sizes from 0.2 KW to MW
- Energy Generation up to 1,00,000 KW per year.
- Can be installed virtually at any site.
- Power stored in batteries.
- Modular Sizes of 0.1KW.
- Can be modular for each use like lights, pumps etc.
- Power stored in batteries.
- Can be installed virtually at any site.



HYBRID WIND SOLAR SYSTEMS.

- Modular Sizes of 0.1KW to 20 KW.
- Can be modular individually for wind and solar energy.
- Power stored in batteries.
- Can be installed virtually at any site.

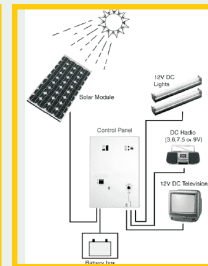

BENEFITS TO COMPLEXES

- Lower cost of Power for Construction, security, fencing etc.
- Eco friendly power adds to marketability of complex.
- Availability of power during no power situations. Can keep minimum utilities operational during power cuts.

RETROFITS IN EXISTING COMPLEXES

- Most of these products and services are viable to retrofit in existing residential and commercial complexes in order to save power and costs.
- Cost benefit analysis can be worked out on case to case basis.



WHY SOLAR ???

- Absolute source of energy
- Can be utilized the most, compared to others
- Continuous development, lead to reduction in cost/Wp
- Favorable government policies globally
- Globally huge demand.



FACTOR IN FAVOUR OF SOLAR ENERGY

- The global demand of solar energy was slightly above 4 GW in 2007 with demand set to rise above 15 GW in 2010.
- Demand for solar will increase phenomenally.

5 KW

Model: SEL 5KW

Numbers of Blade: 3pcs
 Material of Blade: FRP Complex Resin
 Diameter of Wind Turbine: 5.8m
 Start (out-in) wind speed: 3m/s
 Outage (out-out) wind speed: 20m/s
 Rated speed: 220 rotate /min
 Security wind speed: 50m/s
 Wind energy ratio: 45%
 Generator: Permanent Magnetic Generator
 Generator rated power: 5000w
 Max output power: 6500w
 Output voltage: 230v
 Rated current: 26.8A
 Type of off-course: wind direction is decided by dogvane
 Protect: Full automatic intelligent control
 Tower: Flexibility Guy
 Tower height: **12~15 Meters**
 Charging control: Full automatic intelligent control
 Power generation of year: 12500kwh
 Inverter power supply: Pure sine wave inverter
 Matching Battery: **10 Pcs 12 V 150 AH Lead Acid Batteries**
 Time of charging: above 16 hours



Packing volume:

Blade: 3000×300×350mm
 Motor and accessory: 1300×600×800mm
 Tower: 5100×400×500mm
 Weight: 1200kg

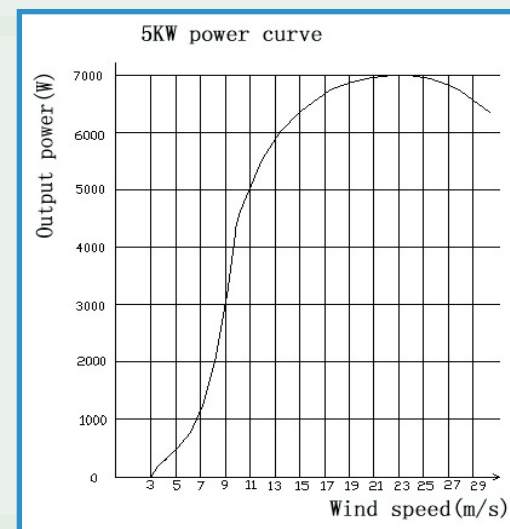

Scope Of Application

TV set (Below 29inch), lighting, DVD/VCD player, Electric Fan, charging
 Water pump, refrigerator, micro wave cooker, air condition, computer
 Washing machine etc

20 KW

Model: SEL - 20KW

Numbers of Blade: 3pcs
 Material of Blade: FRP Complex Resin
 Diameter of Wind Turbine: 12m
 Start (out-in) wind speed: 3m/s
 Outage (out-out) wind speed: 20m/s
 Rated speed: 180 rotate /min
 Security wind speed: 50m/s
 Wind energy ratio: 45%
 Generator: Permanent Magnetic Generator
 Generator rated power: 20000w
 Max output power: 22000w
 Output voltage: 230v
 Rated current: 48.3A
 Type of off-course: wind direction is decided by dogvane
 Protect: Full automatic intelligent control
 Tower: Flexibility Guy
 Tower height: **18~20 Meters**
 Charging control: Full automatic intelligent control
 Power generation of year: 55000kwh
 Inverter power supply: Pure sine wave inverter
 Matching Battery: **40 Pcs 12 V 150 AH Lead Acid Batteries**
 Time of charging: above 20 hours



Packing volume:

Blade: 5100×520×580mm
 Motor and accessory: 1500×875×800mm
 Tower: 5100×700×500mm
 Weight: about 2400kg

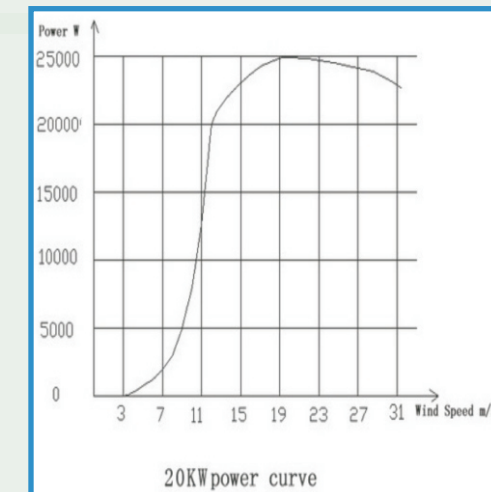

Scope Of Application

This unit can load TV set, DVD/VCD player, Electric Fan,
 Lighting & charging Water pump, refrigerator, micro wave cooker, air
 condition, computer, washing machine etc, which generating can supply
 for Small hotel, small mill, school, bus station, small village,
 Swimming pool etc

अपने घर को रोशान करें अपनी दुनिया रोशान करें



लुगनू सोलर होम लाईटिंग सिस्टम

- पैकेज्ड 12 वोल्ट सिस्टम.
- इस्तेमाल के लिए तैयार किट.
- बिना सूरज रोशनी के 3-5 दिन तक काम करें.
- इस्तेमाल में आसान, रखरखाव रहित.
- कई प्रकार के मॉडलों में उपलब्ध.



सोलर लालटेन

- 3-4 घंटे दैनिक इस्तेमाल.
- चलाने की कोई लागत नहीं.
- लंबा जीवन के साथ सफेद रोशनी.
- लंबा जीवन, रखरखाव रहित बैटरी.
- पोर्टेबल, ले जाने में आसानी.
- मोबाईल चार्जिंग और एफ.एम. रेडियो विकल्प.



मार्गदीप सोलर स्ट्रीट लाइट

- पांच मॉडल एमवी 3, एम वी 6, एम वी 7, एम वी 8 एवं आई बीम
- एल ई डी, सी एफ एल और सॉक्स लैम्प.
- उच्च कार्यक्षमता वाली बैटरियां.
- गेल्वेनाइज्ड स्टील पोल.
- ऑटो ऑन/ऑफ - शाम से सुबह तक चलने वाली.
- लगाने के लिए तैयार, ना के बराबर रखरखाव.



इजीपावर सोलर पावर पैक

- ट्यूब लाईट, पंखों, टीवी, कम्प्यूटर को बिजली देने के लिए ग्रामीण/शहरी घरों के लिए उपयुक्त.
- मॉड्यूलर डिजाइन.
- सोलर व ए.सी. मेन्स पावर दोनों से ही चले.
- 2 घंटे प्रतिदिन का बैकअप, स्टैंड अलोन मोड (सोलर चार्जिंग) व 6 घंटे प्रतिदिन का बैकअप हाईब्रिड मोड में.

Dealer:



Approved by MNRE

Agents/Distributors Enquiries Invited

बिजली बचाएं , पैसे बचाएं , पर्यावरण बचाएं ।

जिंग सोलर वाटर हीटर

- ❑ थर्मोसाइफल एवं प्रेशराइज्ड सिस्टम 100, 200 और 300 लीटर प्रतिदिन क्षमता वाले उपलब्ध.
- ❑ विशेष आकार पी. यू. एफ. इंसुलेटेड टैंक 'स्मार्ट' डिजाइन वाला.
- ❑ टैंक और संग्राहकों के लिए सहायक ढांचा न्यूनतम पूंजी के साथ तैयार.
- ❑ उच्च कार्यक्षमता वाले कापर ट्यूब कलेक्टर.
- ❑ लगाना आसान एवं आकर्षक स्टेड डिजाइन.
- ❑ धूप न होने की स्थिति में इलेक्ट्रीक बेकअप उपलब्ध (मांग अनुसार).



हॉट मैक्स सोलर वाटर हीटर

- ❑ 100, 200, 500 और 1000 लीटर प्रतिदिन क्षमता वाले उपलब्ध.
- ❑ वेक्यूम ट्यूब तकनीक जो कि कठोर जल, जिसकी कठोरता 600 पी पी एम के साथ दक्षता से काम करे.
- ❑ उच्च क्वालिटी ट्यूबों जो बोरोसिलिकेट कांच की बनी हैं.
- ❑ पी यू एफ इंसुलेशन टैंक ये सुनिश्चित करते हैं कि गर्म जल की उष्णता कई घंटों तक बनी रहे.
- ❑ एस एस 304 टैंक जिंकैल्यूम बाहरी क्लैडिंग के साथ.
- ❑ एल्यूमीनीयम सहायक ढांचा.
- ❑ धूप न होने की स्थिति में इलेक्ट्रीक बेकअप उपलब्ध (मांग अनुसार).



अधिक क्षमता वाले सोलर वाटर हीटर

- ❑ 750 एल पी डी और ज्यादा में उपलब्ध.
- ❑ कई हजार एल पी डी की क्षमता.
- ❑ जंग प्रतिरोधी एस एस 304 टैंक .
- ❑ 99% शुद्ध तांबा गर्मी बढ़ाने में मदद करे
- ❑ उष्णता को बेहतर बनाए रखने के लिए टैंक का रबर नाइट्राइल फोम इंसुलेशन.
- ❑ एल्यूमीनीयम, बाहरी क्लैडिंग इसे उपयुक्त बनाती है, यहां तक कि तटीय जलवायु के लिए भी.
- ❑ पी ई-ए एल-पी ई पाईपिंग पानी का स्मूद बहाव सुनिश्चित करती है और उत्तम इंसुलेशन देती है.



वज्र प्लस वाटर हीटर

- ❑ पी यू एफ इंसुलेटेड टैंक जो उष्णता हानि से बचाए, सुनिश्चित करे कि पानी ज्यादा देर गर्म रहे.
- ❑ एस एस 304 स्टील टैंक, उष्ण जंग विरोधिता को बढ़ाए.
- ❑ क्लैडिंग के लिए जी आई पावडर कोटेड शीट.
- ❑ सहायक ढांचा पावडर कोटेड.
- ❑ धूप न होने की स्थिति में इलेक्ट्रीक बेकअप उपलब्ध (मांग अनुसार).
- ❑ प्रेशराइज्ड सिस्टम.
- ❑ 300, 500 और 1000 लीटर क्षमता में उपलब्ध.



Approved by MNRE

Agents/Distributors Enquiries Invited

103/5, Blackie House, Opp. G.P.O., V.T., Mumbai - 400 001. India. Tel. : 91-22-5632 4093,2270 0307,2368 4410,

Fax : 91-22-2261 0803, 2367 9935 Website : <http://www.steelitegroup.com> E-mail : soloar@steelitegroup.com / nikhilshah@steelitegroup.com

वीज वाचवा ! पैसे वाचवा ! पर्यावरण वाचवा !



स्टीलईट सोलार वॉटर हिटर

- थर्मोसाईफन व प्रेशराइज्ड सिस्टम १००, २०० आणि ३०० लिटर प्रत्येक दिवसाला क्षमता असलेले.
- विशिष्ट आकारामध्ये पी. यू. एफ. इंसुलेटेड टाकी "स्मार्ट" डिझाईनमध्ये. टाकी आणि साठवणूक करणाऱ्यांसाठी कमीत कमी जोड असलेला
- साह्यकारी स्टँड.
- अधिक कार्यक्षम असणारे कॉपर ट्यूब कलेक्टर.
- लावण्यासाठी सोपे व आकर्षक स्टँड डिझाईन.
- सुर्यप्रकाश नसताना इलेक्ट्रीक बॅकअप उपलब्ध (मागणीनुसार)

स्टीलईट प्रेशराइज्ड सोलार वॉटर हिटर

- १००, २००, ५०० आणि १००० लिटर प्रत्येक दिवसाला क्षमता असलेले. वॅक्युम ट्यूब तंत्रज्ञान जे जड पाणी, त्याचे जडत्व ६०० पी पी एम च्या
- बरोबर सावधानपूर्वक काम करते.
- अधिक गुणवत्ता असलेली ट्यूब जी बोरेशिलिकेट काचेची बनलेली आहे. एस एस ३०४ टँक जिंकॉल्यूमचे बाह्य आवरण वतौंडगते.
- साह्यकारी स्टँड एल्युमिनिअमचे.
- सुर्यप्रकाश नसताना इलेक्ट्रीक बॅकअप उपलब्ध (मागणीनुसार).



स्टीलईट अधिक क्षमता सोलार वॉटर हिटर

- ५५० एल पी डी आणि यापेक्षाही जास्त क्षमतेमध्ये उपलब्ध. कित्येक हजार एल पी डी ची क्षमता असणारे.
- गंजप्रतिबंध एस एस ३०४ टँक
- ६९% शुद्ध तांबे जी उष्णता वाढविण्यास मदत करते. उष्णतेला व्यवस्थित टिकवण्यासाठी टाकीला नाइट्राइल फोम इंसुलेशनचा रबर. एल्युमिनिअम, बाह्यआवरण वतौंडगते असल्यामुळे उपयोगी, समुद्री भागातील खाऱ्या वाऱ्यापासून धोका नाही.
- पी ई ए, एल पी ई नल जोडणी पाण्याचा प्रवाह सुलभ आणि चांगले इंसुलेशन देते.



स्टीलईट फ्लॉट प्लेट वॉटर हिटर

- पी यू एफ इंसुलेटेड टाकी जी उष्णता हानी पासून वाचवते आणि पाण्याचे तापमान नियंत्रित करते. एस एस ३०४ स्टील टँक, जे उष्णता गंजप्रतिबंध वाढविते.
- वलॅंडिंग साठी जी आई पावडर कोटेड शीट.
- साह्यकारी स्टँड पावडर कोटेड.
- सुर्यप्रकाश नसताना इलेक्ट्रीक बॅकअप उपलब्ध (मागणीनुसार).
- प्रेशराइज्ड सिस्टम
- ३००, ५०० आणि १०० लिटर क्षमतेमध्ये उपलब्ध.



Approved by MNRE

Agents / Distributors Enquiries Invited

Steelite
ENGINEERING LIMITED

Green Energy Division

103/5, Blackie House, Opp. G. P. O., V. T., Mumbai - 400001. India

Tel : +91-22-22700 0307, 2270 0653 / 54 Fax : +91- 22-2261 0803

website : <http://www.steelitegroup.com> email : solar@steelitegroup.com / nikhilshah@hotmail.com

Mobile : +91 98200 70449

फिटे अंधाराचे जाळे... आता प्रकाश प्रकाश



स्टीलईट सोलार होम लाईटिंग सिस्टम

- पॅकेज्ड १२ वोल्ट सिस्टम.
- वापरण्यासाठी तयार किट.
- सूर्यप्रकाशाशिवाय ३ ते ५ दिवस काम करते.
- वापरण्यासाठी सुलभ, देखभाल रहित.
- अनेक प्रकारच्या मॉडलमध्ये उपलब्ध.

स्टीलईट सोलार कॅन्डिल

- पॅकेज्ड १२ वोल्ट सिस्टम.
- वापरण्यासाठी तयार किट.
- सूर्यप्रकाशाशिवाय ३ ते ५ दिवस काम करते.
- वापरण्यासाठी सुलभ, देखभाल रहित.
- अनेक प्रकारच्या मॉडलमध्ये उपलब्ध.



स्टीलईट सोलार स्ट्रीट लाईट

- पाच मॉडल एम वी ३, एम वी ६, एम वी ७, एम वी ८ व आई बीम .
- एल ई डी, सी एफ एल आणि सॉक्स लॅम्प.
- अधिक कार्यक्षम बॅटरी.
- गेल्वनाईज्ड स्टील पोल (स्वांब).
- स्वयंचलित ऑन ऑफ (चालू बंद) सिस्टम,
- सायंकालपासून सकाळपर्यंत चालणारी.
- वापरण्यासाठी पुर्णत तयार व जवळजवळ स्वतः नाहीत.



स्टीलईट सोलार पावर पॅक

- ट्यूब लाईट, पंखे, टिवी, कम्प्यूटर यासाठी ग्रामीण/शहरी भागांमध्ये वीजेसाठी उपयुक्त.
- मॉड्युलर डिझाईन.
- सोलार व प. सी. मेन्स पावर ह्या दोन्हीवर चालते.
- प्रत्येक दिवशी २ तासांचे बॅकअप - स्टँड अलोन मोडमध्ये (सोलार चार्जिंग) व प्रत्येक दिवशी ६ तासांचे बॅकअप - ह्यायब्रिड मोडमध्ये



Dealer:

Approved by MNRE

Agents / Distributors Enquiries Invited

Steelite
ENGINEERING LIMITED

Green Energy Division

१०३/५, ब्लॅकी हाउस, जी. पी. ओ. समोर, छत्रपती शिवाजी टर्मिनल, मुंबई - ४००००१, भारत.

Tel. : 91-22-2270 0307, 2270 0653 / 54 Fax: 91-22-2261 0803, 2367 9935.

Website: <http://www.steelitegroup.com> Email: solar@steelitegroup.com / nikhilmshah@hotmail.com

cees. : 9820070449



Solar Products

Gift of Nature...



...Changed to Power by Steelite

Steelite

Solar Compatible Lantern

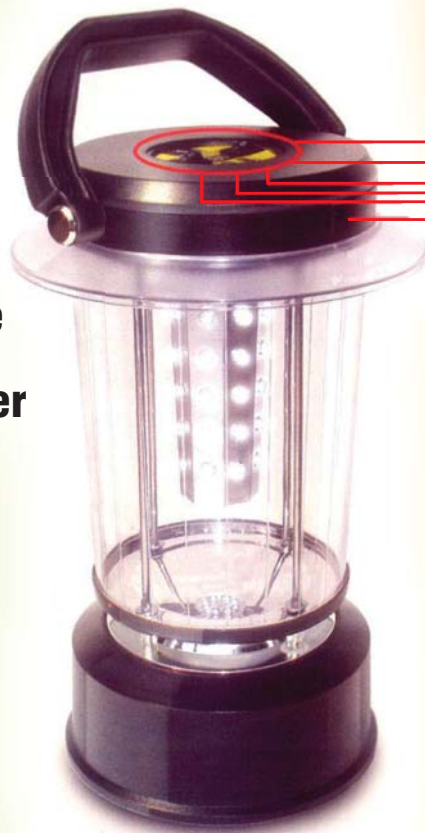

- Mobile Phone Charging Socket
- On / Off Switch
- Battery Charged Indicator
- Battery Low Indicator
- Charging On Indicator
- Lantern charging Socket



With Mobile Phone Charger

A TYPICAL SOLAR PHOTOVOLTAIC SYSTEMS
Solar PV Module (OPTIONAL)

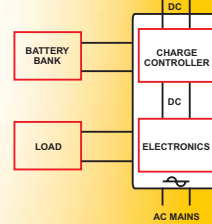
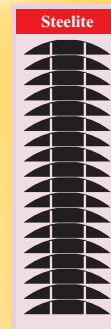

1 Year Warranty



Long Duration Emergency Light



Solar Compatible



Energy Efficient

APPLICATIONS



OFFICE/HOME



WORK SHOP/LABS



HOSPITALS & NURSING HOMES



FISHING



VILLAGE AREA/FARMING



CAMPING/TRACKING



RESTAURANTS / HOTELS



RENEWABLE ENERGY WITH COMPLETE SOLUTION

Blackie House, 1st Floor, W.H. Marg, Opp. GPO, Near CST, Mumbai – 400 001 Tele. : (91-22) 2270 0307 (91-22) 2270 0653
Fax : 91-22-22610803 E-mail : sales@steelitegroup.com samirmshah@hotmail.com Website : www.steelitegroup.com



Solar Products

Gift of Nature...



...Changed to Power by Steelite

About Product

Steelite EMERGENCY LIGHTS are special designed for tough and rigid conditions.

1. International PWM-MOSFET Technology.

PWM-MOSFET Technology are the worlds latest technologies in emergency power supply system. This internationally acclaimed. MOSFET technology is highly recommended as a reliable and efficient power device for all your sensitive equipments or emergency needs. PWM technology is used worldwide to keep the output stable in inverter mode. This blend of PWM-MOSFET technology has unique revolution and has become a matter of pride at the international level.

2. What is special?

- * Very high switching efficiency i.e. Maximum usage of stored energy with least transmission loss.
- * Ensures a stable voltages supply, confirming continuous non-dimming illumination output, during the use of EMERGENCY LIGHT
- * Brighter illumination with longer duration.

3. Provide Effective Protection Against

- * Power Failure
- * Wide voltage Fluctuation
- * Main Supply Noise Like surges, Spikes, Sags etc. During batt , charging.

4. Solar compatible Power electronics, batt. Can be charged with solar photovoltaic module.

5. Mobile Phone charging socket for emergency purpose.

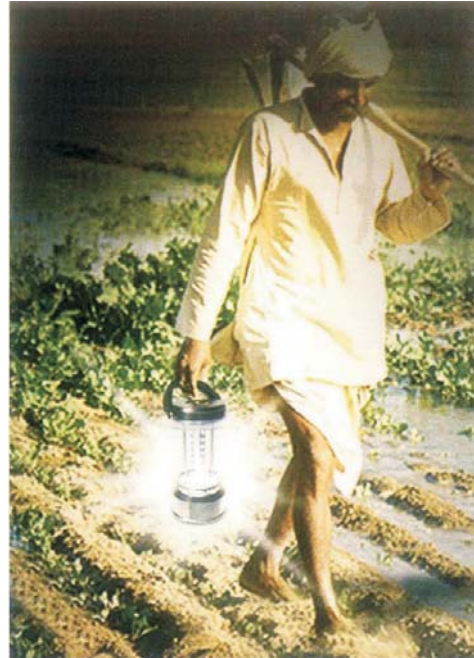

Lightning Lives For Nation's Bright Future

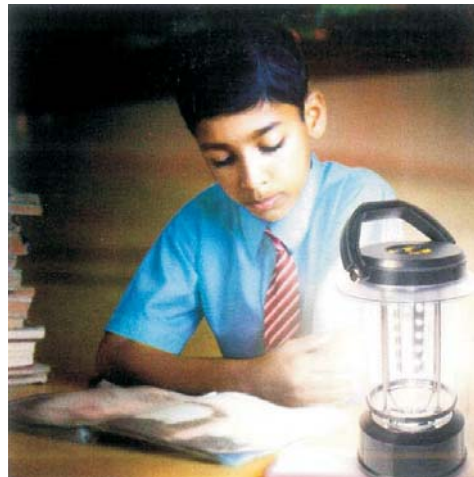
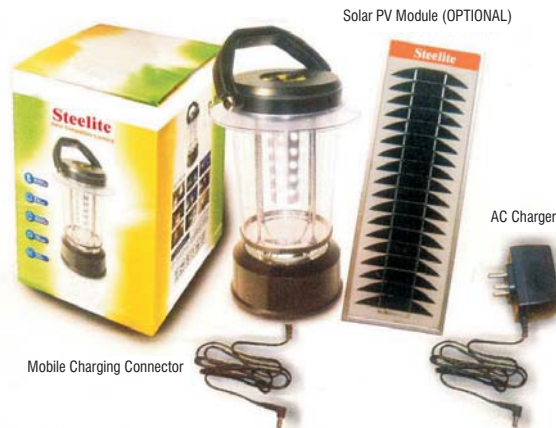

TECHNICAL SPECIFICATIONS

Battery Type	Sealed Lead - Acid Maintenance Free
Dimensions (Dia. x H) mm	(264 x 164) mm



RENEWABLE ENERGY WITH COMPLETE SOLUTION

Blackie House, 1st Floor, W.H. Marg, Opp. GPO, Near CST, Mumbai – 400 001 Tele. : (91-22) 2270 0307 (91-22) 2270 0653
Fax : 91-22-22610803 E-mail : sales@steelitegroup.com samirmshah@hotmail.com Website : www.steelitegroup.com



Steelite

Solar Street Light

सोलर स्ट्रीट लाईट
सोलार स्ट्रीट लाईट्स

FEATURES

- Telescopic pole
- Solar Panel Pan Tilt Arrangement
- Light Rotation 360°
- Folding Fittings For Easy Transportation
- Dusk to Dawn Operation

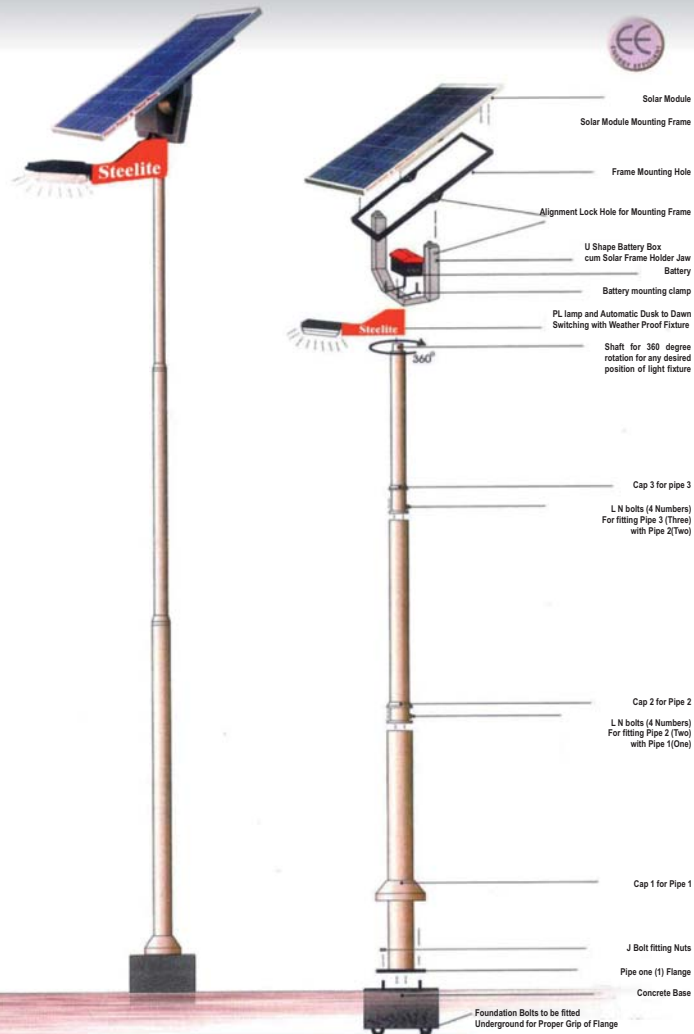



सोलार स्ट्रीट लाईट्स

Solar Street Light

सोलर स्ट्रीट लाईट



SOLAR STREET LIGHTS / COMPOUND LIGHTS:

A Product which is designed in a unique way. It is not only good looking but also loaded with features. Pole is folding & packed in 6.5 ft pack. Thus very easy to transport. It is epoxy coated (heat painting method). Thus lasting for longer period as well as good finish.

SMF Batteries are used making the product almost maintenance free. Batteries are kept as a height of 15 ft. in locked box. This helps in reducing the misuse & Theft of batteries also it helps in reduction of transmission loss thus giving a longer backup. We can rotate the light fitting at 360 angle making it more useful in case of any requirement.





GREEN ENERGY DIVISION



Gift of Nature...

Changed to Power by **Steelite**

Steelite Solar Submersible Pump



Features

- Designed for underwater applications - No need of priming and foot valve
- Can also be used for out of water applications.
- Easy installation- Foundation and installation platform or pump house not required.
- Can withstand wide voltage fluctuations from 200-440 Volts.
- Water shower arrangement for out of water applications.
- Designed to prevent overloading and motor burning.
- Dynamically balanced rotating parts to ensure minimum vibrations during running.
- Replaceable wearing parts and hence longer life.
- Easy maintenance and spares availability.

Applications

- Submerged pump in Fountains, Wells, Sumps and Water tanks.
- Water supply for domestic use in high rise Apartments, Buildings and Hotels.
- Gardening and sprinkler/conventional irrigation.
- Industries, for clear water handling.
- Drinking Water Supply.
- Livestock Watering.
- Etc.



Steelite Engineering Limited - Green Energy Division, Blackie House, 103 W. H. Marg, 1st Floor, Opp. GPO, Near CST, Mumbai - 400 001. India.
 Tel.: +91 22 2270 0307 / 653 / 654 Fax : 2261 0803 Email : sales@steelitegroup.com / samirshah@hotmail.com / samir@steelitegroup.com

Steelite Solar Submersible Pump

Characteristics

- lift upto 400m
- flow rate upto 11 m³/h
- simple installation
- maintenance free
- high reliability
- life expectancy
- cost-efficient pumping

Components

Controller

- controlling of the pump system and monitoring of the operating states
- mounted at surface (no electronic parts submerged)
- two control inputs for well probe (dry running protection), float or pressure switches, remote control etc.
- automatic reset 20 minutes after well probe turns pump off
- protected against reverse polarity, overload and high temperature
- speed control, max, pump speed adjustable to reduce flow rate to c.30%
- solar operation : intergrated MPPT (Maximum Power Point Tracking)
- battery operation : low voltage disconnect and restart after battery has recovered
- max. efficiency 92% (motor + controller)
- enclosure : IP 54 (sealed, weatherproof)

Motor

- brushless DC motor
- no electronics inside motor
- water filled
- IP68, pressure balanced, unlimited submersion
- dynamic slide bearing, material : carbon/ceramic
- wetted material : stainless steel (AISI 316), POM, rubber, cable drinking water approved.

Pump End (PE)

- high life expectancy
- non-return valve
- dry running protection (optional)
- material : stainless steel (AISI 316), rubber

Solar Photovoltaic Panels

- amorphous or crystalline solar cells
- various module ratings such as 37, 50, 75, 100 Wp etc. can be configured
- manufacturer guarantee for 20 yrs.

HR Pumps Only

- helical rotor pump (positive displacement pump)
- two main parts only : stator and rotor, field serviceable
- stator : geometry made of abrasion resistant rubber
- rotor : stainless steel, hard chrome plated, abrasion resistant
- more resistant to damage by sand than other pump types
- self-cleaning

Solar Variable DC

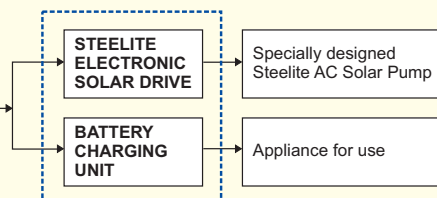

Sr. No.		1	2	3	4	5	6	7	8	9
Model No.		SEL/SSP/1	SEL/SSP/2	SEL/SSP/3	SEL/SSP/4	SEL/SSP/5	SEL/SSP/6	SEL/SSP/7	SEL/SSP/8	SEL/SSP/9
Lift	Lift (ft)	1200	1200	1200	200	400	600	800	900	1000
Flow	lph	1000	2000	100	1000	1000	1000	1000	1000	1000
Hp	hp	3.32	6.64	0.34	0.55	1.11	1.66	2.21	2.49	2.77



Go For Steelite Structure Supporting System For Elegance & Strength



Approved by Leading International Consultants BECHTEL, GEC ALSTOM, ABB,
UDHE., TOYO, KVAERNER, L & T, SIEMENS etc.,

Agents/Distributors Enquiries Invited

Go For Steelite Structure Supporting System For Elegance & Strength

Fixing Systems for Solar Energy Installations



Thermal Collectors



Photovoltaic Modules

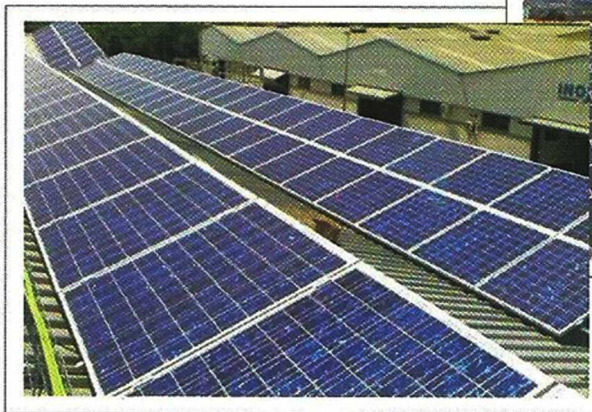

KIT for thermal collectors

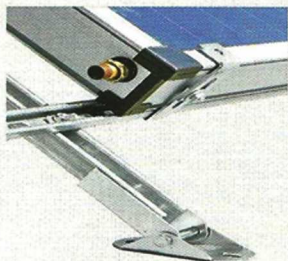

Detail view Low-end

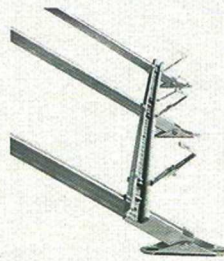

Low-end Bracket Kit
for 2 collectors

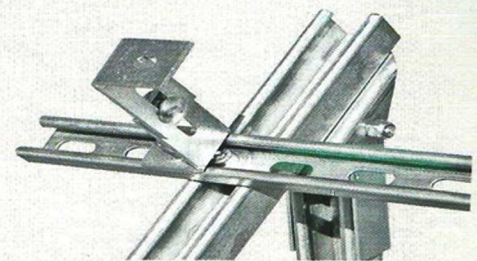

Jointed Regulable support
and Top-end Bracket



Approved by Leading International Consultants BECHTEL, GEC ALSTOM, ABB,
UDHE., TOYO, KVAERNER, L & T, SIEMENS etc.,

Agents/Distributors Enquiries Invited

Go For Steelite Structure Supporting System For Elegance & Strength

Components of the kits for thermal collectors

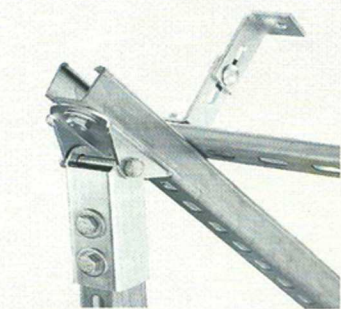
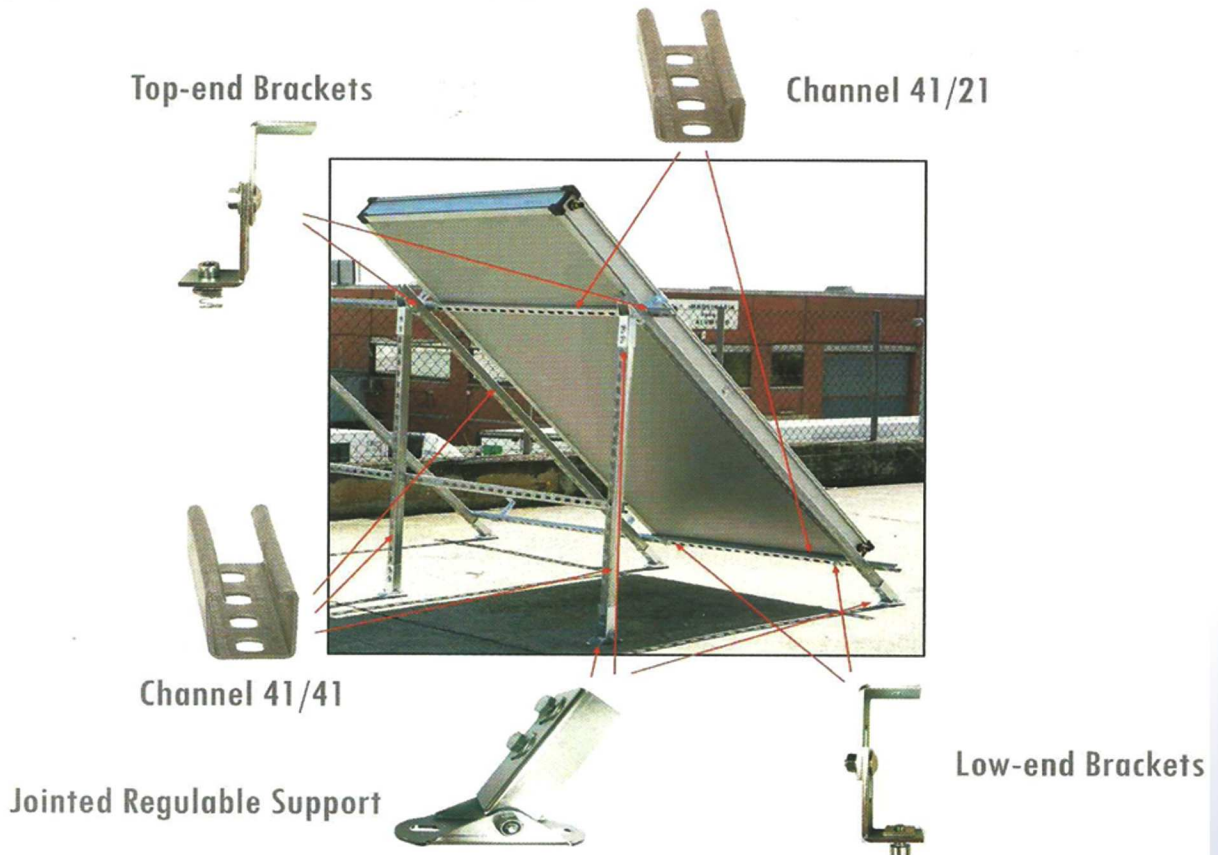

Detail View Top-end Bracket

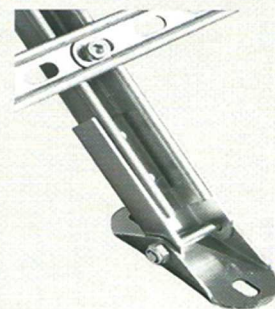

Detail View Top-end Bracket



Approved by Leading International Consultants BECHTEL, GEC ALSTOM, ABB,
UDHE., TOYO, KVAERNER, L & T, SIEMENS etc.,

Agents/Distributors Enquiries Invited

Go For Steelite Structure Supporting System For Elegance & Strength

Kit for 1 Collector

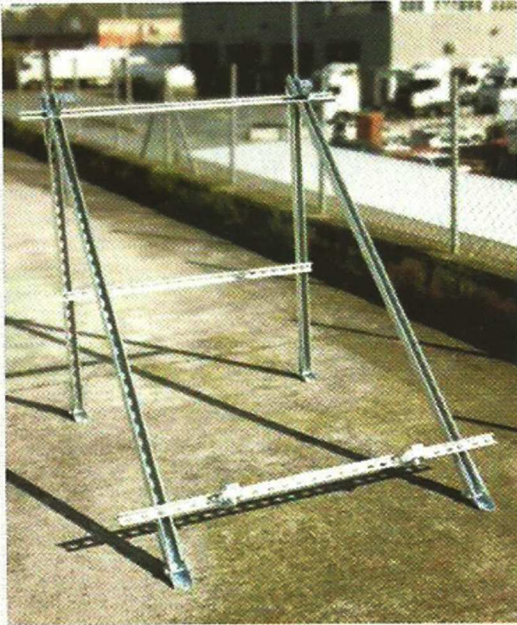

Front View



Rear View

Kit for 2 Collector



Front View



Side View



Rear View



Approved by Leading International Consultants BECHTEL, GEC ALSTOM, ABB,
UDHE., TOYO, KVAERNER, L & T, SIEMENS etc.,

Agents/Distributors Enquiries Invited

Go For Steelite Cable Support System For Elegance & Strength

Manufacturers of : Standardized, Complete Cable Support Systems Comprising of full range of Cable, Ladders, Ventilated Trays & Cables Ducts and also Supports & Accessories as per International Standards (NEMA).

Specialist in : Struts Supports & Accessories Cable Tray Ladder & Perforated Type Finish

•Hot Dipped Galvanised •FRP •Aluminium •Stainless Steel •Epoxy •Enamel painted •PVC Coated

Also Manufacturers of : Transmission Line Towers, Substation Structures, Earthing Materials, Gratings, FRP Cooling Towers, Electric Overhead Line Materials, etc.



FEATURES

- Easy to install.
- Designed for quick assembly for giving perfect fitting of cable trays in neatly carrying cables during entire installation & with finish to give elegant look at economical cost.
- Designed to withstand the dynamic loads, encountered during installation.
- High quality Hot Dip Galvanizing gives complete protection from corrosion.
- The perfect surface treatments are maintenance free for high life expectancy as good as the life of your installation.
- All welded construction with a smooth inner surface to prevent cable damage.
- All necessary Direction, Fittings, Support Materials, Accessories & Connectors are available to complete the System.

QUALITY ASSURANCE

- Independent Quality Assurance Department to supervise & maintain quality.
- Technically qualified / experienced personnel to exercise quality control from the stage of procurement of raw material to handling of finished products.
- All quality assurance method at factories & plants are planned & co-ordinated, specially in case of Testing.
- Sharp edges are rounded off & Rough edges are removed to ensure safety of cables.
- Galvanising plant with most modern facilities.
- Full fledged laboratory & Testing Facilities.

SPECIALISATION

INTRODUCED HOT DIP GALVANISED

Light weight sheet metal cable tray system which reduces the dead weight of tray increasing load capacity, economy in material, assembly cost & installation time. Also supplier of Hot Dip Galvanised steel structures, Earthing strips, Poles & Rebars, Bolts & Nuts by special centrifugal method.

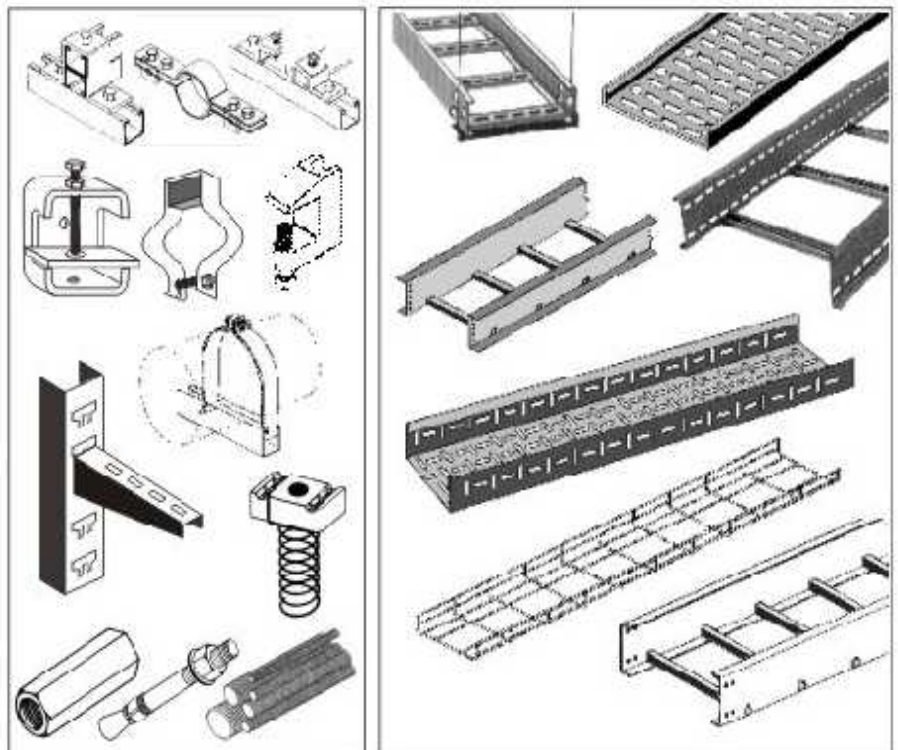

Approved by Leading International Consultants BECHTEL, GEC ALSTOM, ABB, UDHE., TOYO, KVAERNER, L & T, SIEMENS etc.,

Agents / Distributors Enquiries Invited



Our other range of products



COOLING TOWERS : FRP BOTTLE & SQUARE TYPE, NATURAL DRAFT IN TIMBER SINGLE AND DOUBLE ENTRY COUNTER FLOW



WASTE WATER TREATMENT PLANTS, POTABLE WATER TREATMENT PLANTS, CARIFICATION SYSTEMS, FILTRATION SYSTEM (WATER & WASTE WATER), PUMPING STATION, DISSOLVED AIR FLOTATION, AERATED GRIT CHAMBERS, AIR STRIPPERS (UCO & AMMONIA REMOVAL), INDUSTRIAL WASTE TREATMENT PLANTS, SEWAGE RECYCLING SYSTEM ETC.

HOT DIP GALVANISING



FRP/ALUMINIUM STRUCTURAL-I BEAM, CHANNELS, ANGLES, COMPOSITES ETC.



MALLEABLE CASTINGS, S.G. IRON CASTINGS. CAST IRON CASTINGS.



Approved by Leading International Consultants BECHTEL, GEC ALSTOM, ABB, UDHE., TOYO, KVAERNER, L & T, SIEMENS etc.,

Agents / Distributors Enquiries Invited



Our other range of products

TRANSMISSION LINE TOWERS, OVERHEAD LINE MATERIALS,
CROSS ARMS, STAY RODS, TENSION CLAMPS, CONDUCTORS, HOOKS , P G CLAMPS,
TRUSSING TACKLES, POLE LINE HARDWARE FOR ELECTRICAL DISTRIBUTION,
TELECOM POLE LINES & CATV ACCESSORIES,
OHE STRUCTURE, SUBSTATION STRUCTURE,
EARTHING LIGHTNING MATERIALS, HARDWARES, FASTENERS.

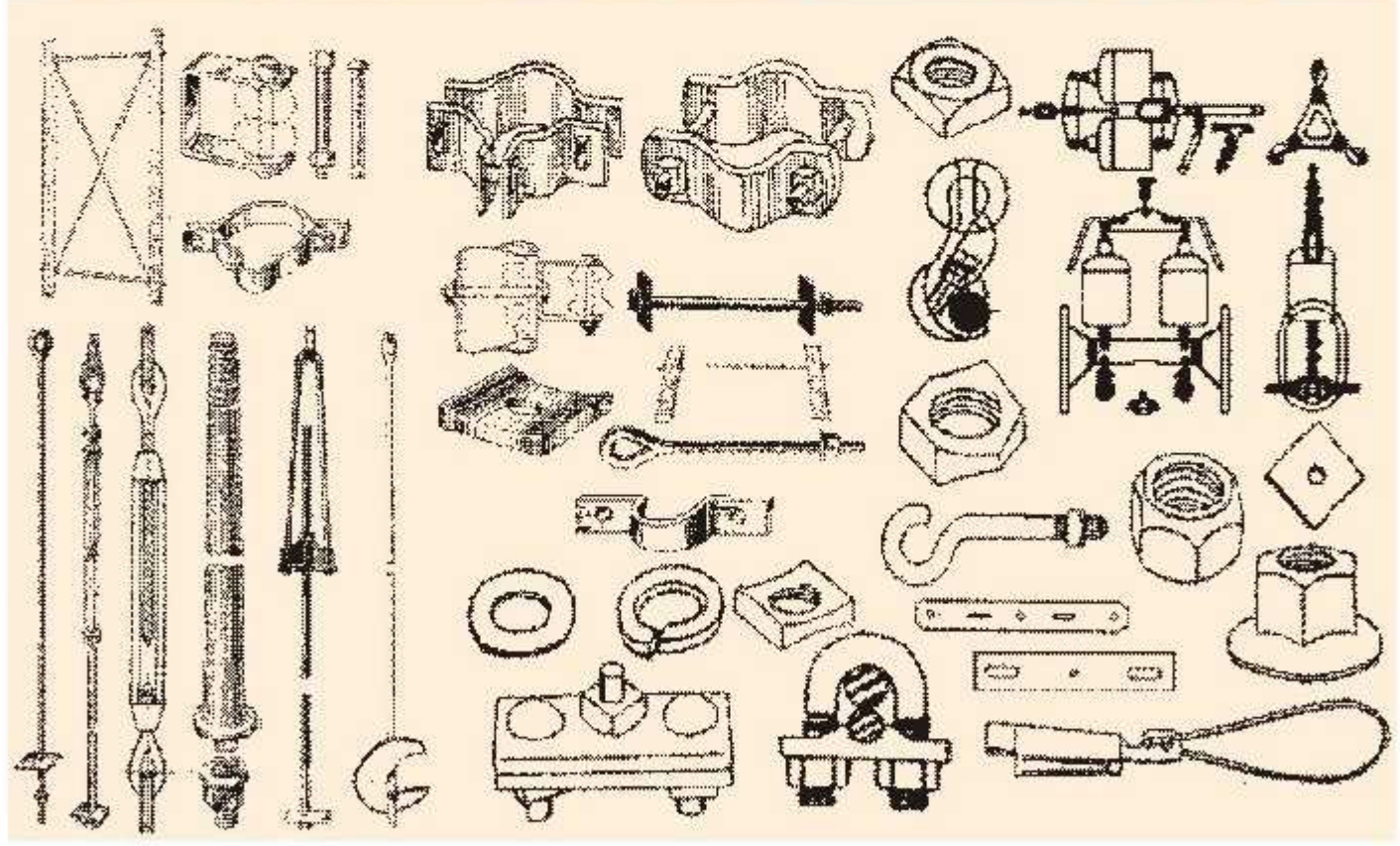

Approved by Leading International Consultants BECHTEL, GEC ALSTOM, ABB,
UDHE., TOYO, KVAERNER, L & T, SIEMENS etc.,

Agents / Distributors Enquiries Invited



Our other range of products

GRATING

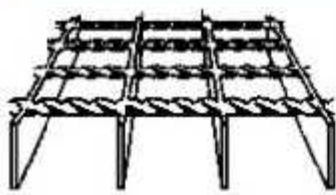

GUARDRAILS / CRASH BARRIERS



EARTHING & LIGHTNING PRODUCTS

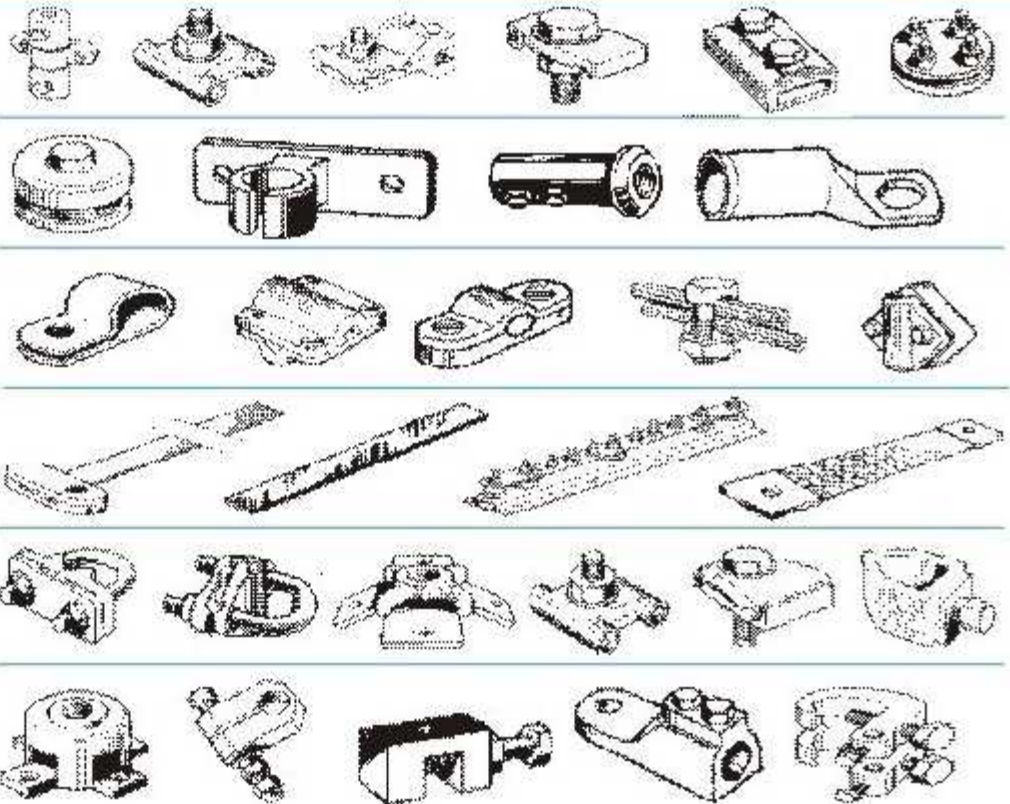
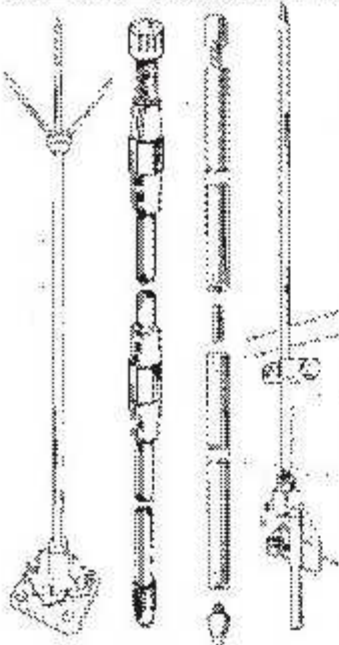
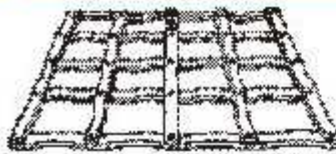

Approved by Leading International Consultants BECHTEL, GEC ALSTOM, ABB, UDHE., TOYO, KVAERNER, L & T, SIEMENS etc.,

Agents / Distributors Enquiries Invited

103/5 Blackie House, Opp. G.P.O., V.T., Mumbai - 400 001 India. Tel. : 91-22-5632 4093, 2270 0307, 2368 4410, Fax : 91-22-2261 0803, 2367 0035 Website : <http://www.steelitegroup.com> E-mail : sami@steelitegroup.com / nikhilmshah@hotmail.com

Go For Steelite Structure Supporting System For Elegance & Strength

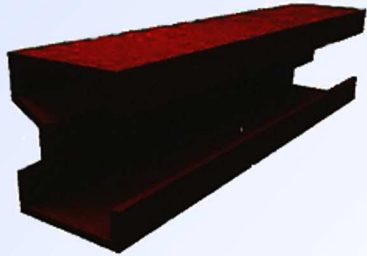

SIGMA

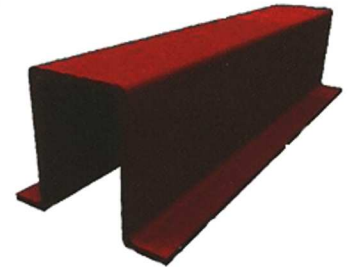

OMEGA

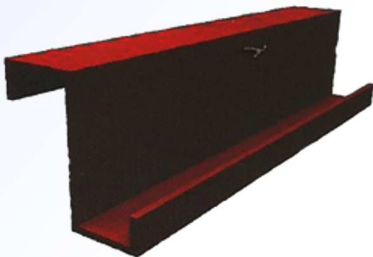

Z



SQUARE PIPE

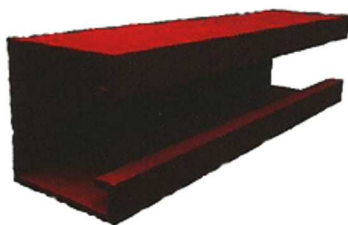

CHANNEL

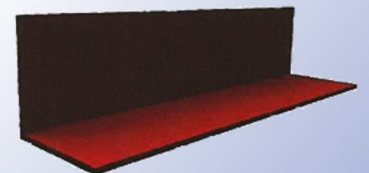

L ANGLE



Approved by Leading International Consultants BECHTEL, GEC ALSTOM, ABB,
UDHE., TOYO, KVAERNER, L & T, SIEMENS etc.,

Agents/Distributors Enquiries Invited

Go For Steelite Structure Supporting System For Elegance & Strength

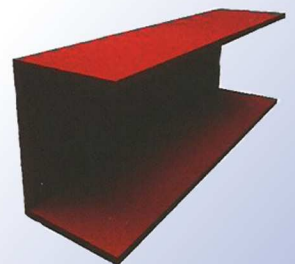
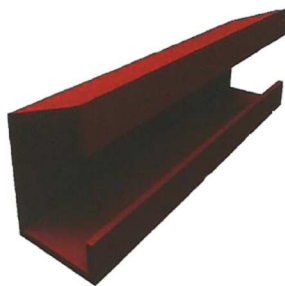
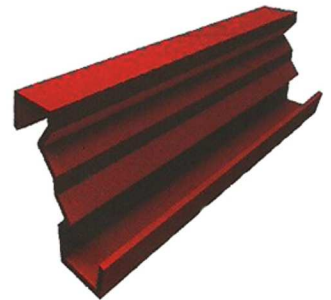

Approved by Leading International Consultants BECHTEL, GEC ALSTOM, ABB,
UDHE., TOYO, KVAERNER, L & T, SIEMENS etc.,

Agents/Distributors Enquiries Invited



Blackie House, 103, W.H. Marg, CST, Mumbai-400 001. Tel: 2270 0653-654 – Fax: 2261 0803
Email: sales@steelitegroup.com–samirmshah@hotmail.com –Website: www.steelitegroup.com
GREEN ENERGY DIVISION

Ref: SEL/INTRO/SOLAR/GED/SAMIR
Date : 1st January, 2013

Sub : Introduction of Steelite Engineering Limited.

Dear Sir,

We introduce ourselves as leading manufacturer and supplier of Fabricated Structures, Struts Supports, Cable Tray Support Systems, Roofing Sheets, Pre-engineered Building Structures, Warehouse Structures, Cold Roll Forming, Gratings, Handrails, Ladders, Scaffoldings and huge variety of Fabricated and Galvanized Structure for electrical and mechanical items.

In India we are the pioneers to manufacture and market Cable Trays at a time when this was imported from overseas. In course of time, with rapid growth in infra-structure and electrification in India, our Company, too, expanded to include mechanical and civil-engineering to cope up with the ever-rising demand for its products and services.

We have also ventured out into Renewable energy Sector. Our Green Energy Division is set to take the company to new levels of success. Our products include Solar panels, Windmills, Energy efficient LED Lights for complete renewable energy solution along with many value added products to minimize cost and increase energy efficiency

Our products are manufactured to International Standards.

Our products and services account for the following items:-

ELECTRICAL INSTRUMENTATION: Cable Tray Support System-hot dip galvanized / FRP/PVC/ Aluminum Earthing Materials, Earthing Strips, Earthing Electrodes- Galvanised copper, Steel Accessories, Switch Gears, Transformers, Heat Exchangers, Boilers.



Blackie House, 103, W.H. Marg, CST, Mumbai-400 001. Tel: 2270 0653-654 – Fax: 2261 0803
Email: sales@steelitegroup.com–samirmshah@hotmail.com –Website: www.steelitegroup.com
GREEN ENERGY DIVISION

MECHANICAL : Steel Bridges, Steel Structures, Crash Barriers/ Guard Rails/ Floor Gratings, Walkways, Piping structures, Transmission line, Towers, Pre-engineered building structures, Warehouse structure, Roofing sheet, FRP/Aluminium Structural – I Beam, Channels, Angles, Composites, Strut Channel, Combination Strut Channel, C – Channel Straight Support, C – Channel Reinforced Support, Concrete Insert C-Channel, Suspension Channel Support, Channel Hanger Support, C-Channel Nuts Zinc Plated, C-Channel Fixing Bolt, Z-Bracket, Beam Clamp, Swivel Hook, Hanger Rod, Banding Clips, Pressure Vessels, Specialised Sky Light System, Turbo Ventilating System.

CIVIL: Tor Reinforced Bars –hot dip galvanized Epoxy- coated, Transmission Line Towers, Tele-Com Towers, Sub-Station Cross Arms, Stay Road, Tension Clamps, Conductors, Hookstrussing Tackles, Pole Line Hardware, Telecom Pole Lines, Earthing & Lighting Materials, Pipe Lines.

CASTINGS: Cast- Iron Castings, Malleable Castings, SG Iron Castings, Shot Blasted Frames, Galvanized Purlins & Girts, Roof AD Wall Panel, Standing Seam Roof, Bolt Hidden Wall Panels.

SOLAR PRODUCTS: Solar Hot Water Systems, Solar Street Lights, Solar Submersible Pumps, Solar Water Pumps, Solar Home Light System, Solar Lanterns, Solar Power System, Solar Roof Top Power System.

SERVICES: Design Consultancy Services / Hot Dip Galvanizing of 5000 MT PM, Cooling Towers, ERP Bottle & Square Type, Natural Draft In Timber Single And Double Entry Outer Flow, Waste Water Treatment Plants, Potable Water Treatment Plants, Carifcation Systems, Filtration Systems, Pumping Station, Dissolved Air Floatation, Aerated Grut Chambers, Air Strippers, Industrial Waste Treatment Plant, Sewage Recycling Systems, Electromechanical Work, Balance of Plants, Sheeting/Cladding, Erection, Maintenance, Supervision Contract

ENGINEERING DESIGN CONSULTANCY SERVICES:

We have elaborate arrangements backed by qualified and experienced staff with expertise in Engineering Design Field. This has been and is one of the backbones of our Research and Development Wing. With the idle capacity readily available there, we hope, this could be made more dynamic and made to perform and get optimum result. As such, an association with you would be like a shot – in-the-arm for generation of better business to meet both / national and international demands. However, to make this happen we got to do “first thing first”.



Blackie House, 103, W.H. Marg, CST, Mumbai-400 001. Tel: 2270 0653-654 – Fax: 2261 0803
Email: sales@steelitegroup.com–samirmshah@hotmail.com –Website: www.steelitegroup.com
GREEN ENERGY DIVISION

To digress a little here, we are well-equipped to manufacture about 2500 tons per month and in hot dip-galvanizing, we can galvanize materials up to 22 feet in length and this service enables us to remain more competitive, economical and faster in meeting time-bound deliveries. Products like overhead line materials are hot dip-galvanized in addition to engineering tools and other machine parts with or without galvanizing plus fabricated steel pipes, poles, Tubular and other steel Structures, Sub-station structures besides various other hot dip galvanized steel, aluminum fabricated items as per drawings and specifications.

We also undertake regular job orders for hot dip galvanizing in our plant run on state-of-the-art technology.

We are well equipped to manufacture about 500 ton of above items per month with spare-capacity to meet any contingency. This enables us to take added advantage for fulfilling deliveries and in exercising strict-quality check in every stage of production. Technically well qualified and experienced staffers also help in the selection and use of right type of Structures & cable trays for end-users against detailed specifications in advance.

We are approved by the well known International Consultants like Bechtel-International Inc. ENRON-US for their western India project know as Dabhol power project, beside Nuclear Power Corporation, Siemens, Areva, ALSTOM, ABB., Humphreys & Glasgow U.K., Simons Eastern USA., Canadian Metchem Canada, Snam Projecti-Italy., Spie Capag-France., Ewbank Preece Ltd. U.K., NKK-Japan and many more like EIL-Engineers India Ltd., Tata Consultants, Davy Power gas, ICB Ltd, UDHE (I) Ltd etc.

Our other esteemed customers include state giants like Bharat Heavy Electricals (BHEL), National Thermal Power Corporation (NTPC), State Electricity Boards, Chemical and Fertilizer Corporation, Ship yards and ports, Infra-structure, Builders developers etc.

We are also exporting our products to Middle East, Far East, Caribbean, African and Latin American countries, also to Western Europe, in bulk quantities.

Apart from products mentioned before, we also have exclusive arrangements with our subsidiary and Joint Venture Partners for their wide range of Engineering etc for Solar Projects.

In the light of what has been written before, to be convinced of our capacity to meet demanding engineering challenges to the last nut in detail, to the changing paradigms of product concepts, their engineering design needs, contours of



Blackie House, 103, W.H. Marg, CST, Mumbai-400 001. Tel: 2270 0653-654 – Fax: 2261 0803
Email: sales@steelitegroup.com–samirmshah@hotmail.com –Website: www.steelitegroup.com
GREEN ENERGY DIVISION

presentation product-wise and project-wise to the last detail, be it electrical, mechanical or civil, architecturally in all its intricate symbolisms where what matters is the tangible final product in material terms with economy , best look and durability to last for the money one may spend , we hope, we have said it all. And, this, we guarantee, too. Yet seeing is believing.

Just to mention we are Executing Projects and Setting up our Solar System for Various Branches of Bank of India copy attached here with for your ready ref.

So, we say, let's make a beginning and see how things work.

Awaiting your considered views earliest and we remain.

Thanking you,

Yours truly,
For STEELITE ENGINEERING LTD

Samir Shah
Managing Director